

REVISIONS

ZONE	REV.	DESCRIPTIONS	DATE	APP.
------	------	--------------	------	------

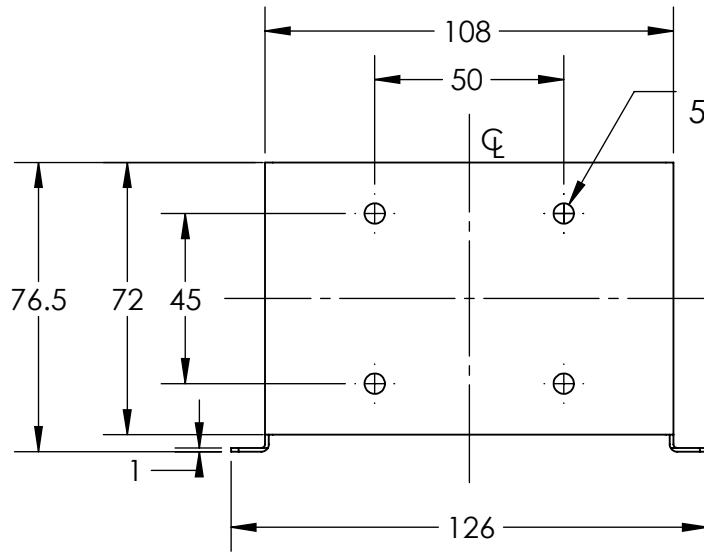

4X  $\phi$   
5.40 THRU ALL

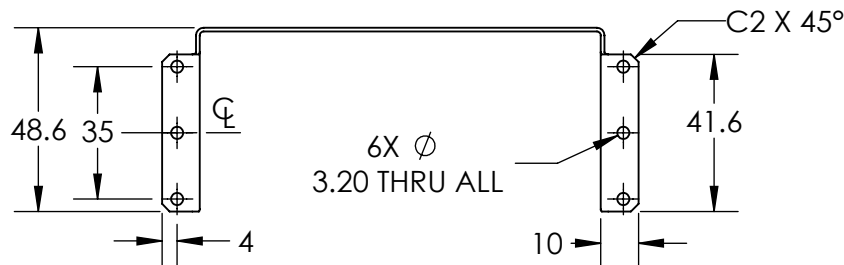
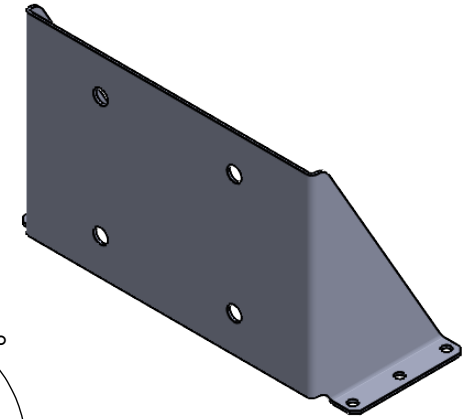
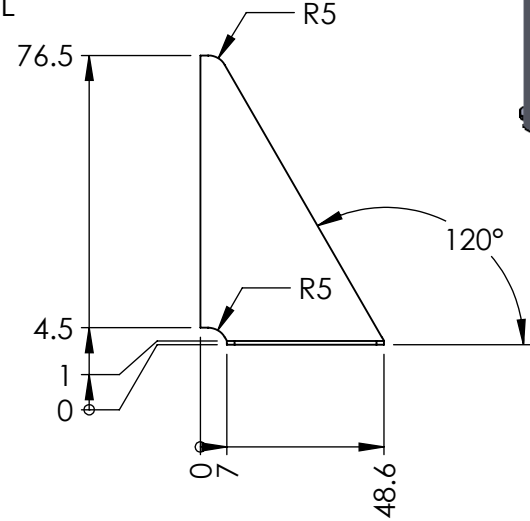

6X  $\phi$   
3.20 THRU ALL

COLOR	WAVE LENGHT
RED:	630nm
GREEN:	525nm
BLUE:	470nm
WHITE:	--
IR 850:	850nm
IR 940:	940nm
UV:	375nm
RGB:	620nm/525nm/470nm

DESIGN BY	NIZAM	UNIT:	PRODUCT SERIES: CAS2 SERIES				
CHECK BY	KB TAN	MM					
DATE	30/7/2021	REVISION:					
MATERIAL	STAINLESS STEEL 1.0MM	01	TITLE	BRACKET	COLOUR:	-	-
FINISHING	HAIRLINE	SCALE:	PART NO	-	VOLTAGE:	-	-
QTY	1	1 : 2	DWG NO	CAS2-00-080-BRACKET-01(REV01)	CURRENT:	-	-
					POWER:	-	-
					SHEET 1 OF 1		

